

Pyrokinesis Technology (OPC) Private Limited deals in all kind of Fire Protection Equipments Supplier and Service.

Our Product Range:

- ❖ Fire Extinguishers
- ❖ Fire Alarm System
- ❖ Fire Hydrant System
- ❖ Fire Sprinkler System
- ❖ Fire Suppression System
- ❖ Fire Pumps
- ❖ Fire Panels
- ❖ Signages
- ❖ CCTV Systems
- ❖ P.A.Systems

Our Services:

- Design
- Supply
- Installation
- Testing & Commissioning
- Maintenance
- Risk Analysis

COMMERCIAL BUILDINGS

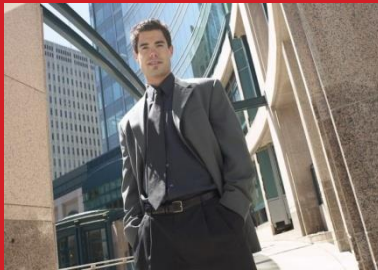

HOSPITALS & NURSING HOMES



RESTAURANTS



GOVERNMENT BUILDINGS



SCHOOLS & UNIVERSITIES



MANUFACTURING FACILITIES

SINGLE SOURCE SOLUTION

WHY SHOULD FIRE PROTECTION BE A TOP PRIORITY IN YOUR COMPANY?

The safety and security of your employees, customers and company assets are the reasons for making fire protection a top priority in your company. Without a quality fire protection program, you may be putting the future of your company at risk.

WHY DO I HAVE TO HAVE MY EQUIPMENT SERVICED?

State building and fire codes require building owners to install and maintain fire protection equipment. Also, insurance carriers require that fire protection equipment be inspected and serviced by trained individuals in order to qualify for insurance coverage. The codes provide a time table for when fire protection equipment must be inspected and serviced.

PRODUCT	SCHEDULE FOR MAINTENANCE
Fire Extinguishers	Annual Inspection
Fire Hydrant System	Quarterly/Annual Inspection
Sprinkler System Service	Quarterly/ Annual Inspection
Fire Alarm Systems	Annual Inspection
Fire Alarm/Security System Monitoring	Monthly Test Signals by Pyrokinesis
Kitchen Fire Suppression Systems	Semi- Annual Inspection
Dry Chemical Fire Suppression Systems	Semi- Annual Inspection
CO ₂ Fire Suppression Systems	Semi- Annual Inspection
FM-200 / NAF S125 Suppression Systems	Semi- Annual Inspection

WHY SHOULD I CHOOSE PYROKINESIS TECHNOLOGY?

Pyrokinesis Technology (OPC) Pvt. Ltd is a full service fire protection and security company that provides single source solutions for all your fire protection needs. Pyrokinesis is always ready to serve you with expert technicians and 24-hour emergency service. In addition, we offer professional fire training programs. Trained instructors are available to conduct hands-on firefighting demonstrations for your employees.

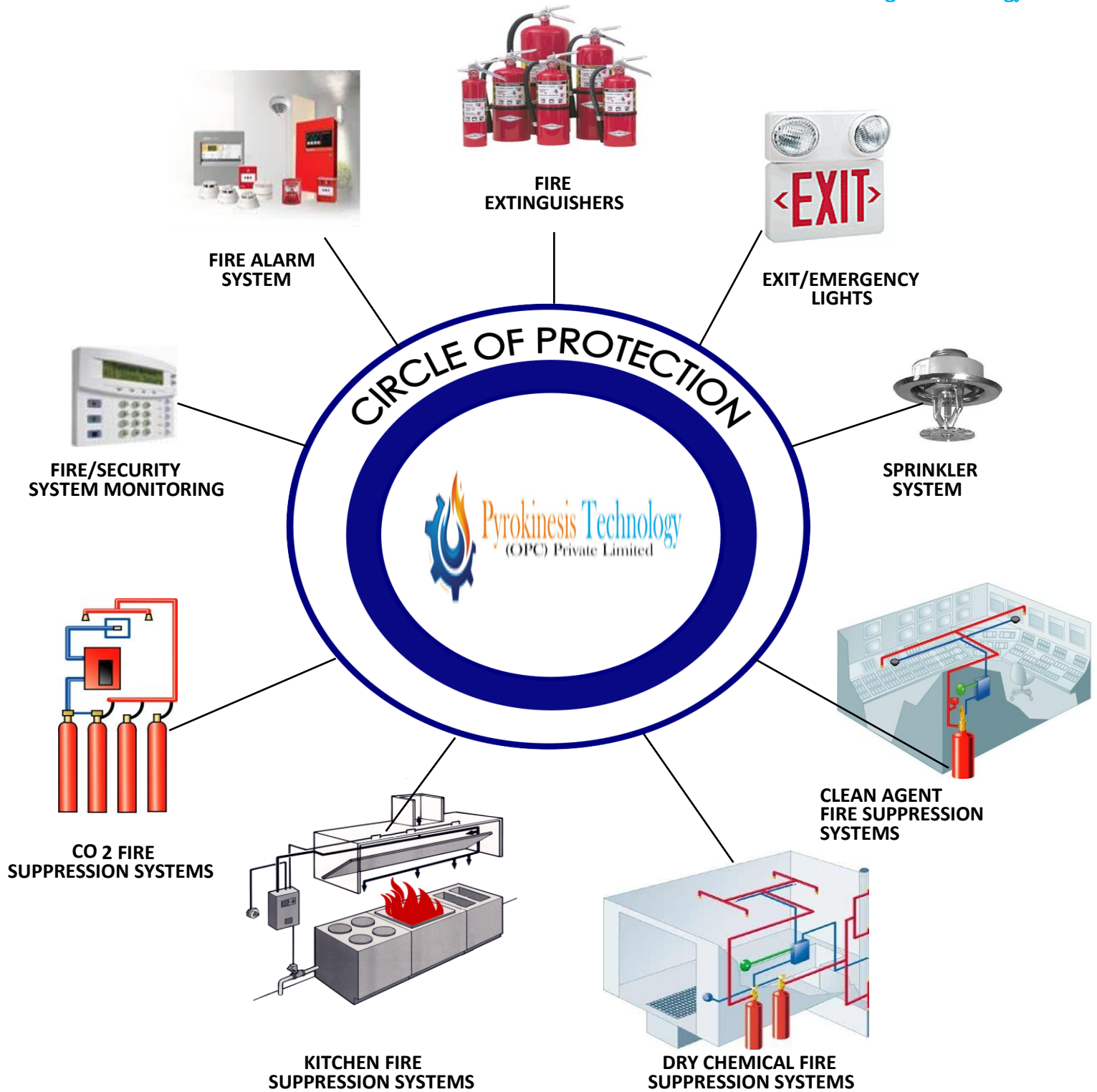

One Call Does It All!

Fire Extinguishers (Portable & Wheeled Type)

We offer an extensive range of extinguishers, from general purpose fire extinguishers to specific applications e.g. electrical fire, in a variety of sizes and finishes to meet your specifications and needs.

Each extinguisher is checked and approved before installation and is regularly inspected by our experienced technicians to ensure it is still in good working condition. We also offer training in the use of fire extinguishers.

A fire extinguisher is an active fire protection device used to extinguish or control small fires, often in emergency situations. It is not intended for use on an out-of-control fire, such as one which has reached the ceiling, endangers the user (i.e., no escape route, smoke, explosion hazard, etc.), or otherwise requires the expertise of a fire department.

Types of Fire Extinguishers



**Water Spray
Extinguisher - Class A**



**Foam Extinguisher
(AFFF) - Class A, B & C**



**Powder Extinguisher
(Multi-Purpose) -
Class A, B & C**



**Carbon Dioxide
Extinguisher - Class B
/ Electrical Hazard**



Wet Chemical - Class A & F

To find out more about our Fire Extinguisher range and Services call on **+91-7892890889** or visit **www.pyrokinesistech.com**

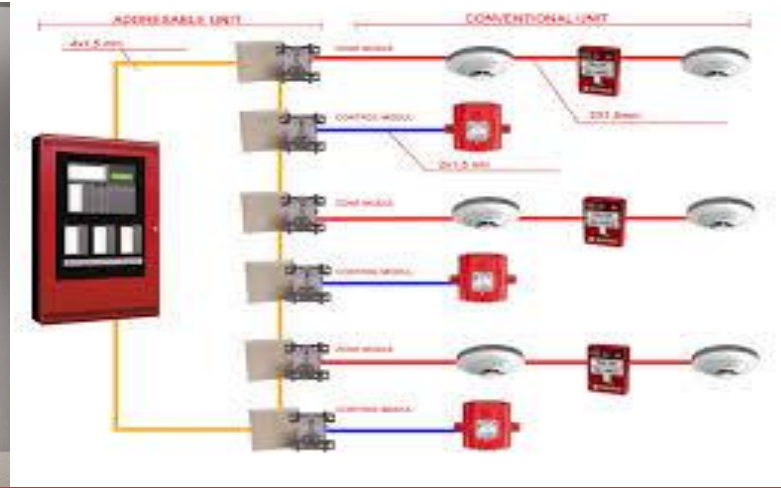
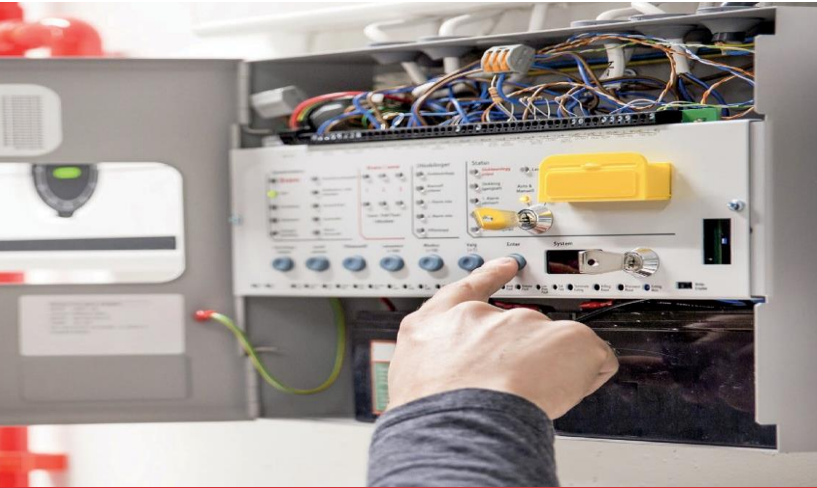

Fire Detection and Alarm System

A fire alarm system is number of devices working together to detect and warn people through visual and audio appliances when smoke, fire, carbon monoxide or other emergencies are present.

We offer a comprehensive range of conventional as well as addressable fire alarm systems, which are used to detect fire occurrence or any intrusion detection in a particular area.

At Pyrokinesis Technology we're not restricted to any one manufacturer. As an independent Fire Safety specialist, we can supply, install and service all types and manufacturers of alarms.

We design Fire Detection System as Per Local Standard, NFPA-72, NBC, IBC & IS standards.

We do Following Types of Fire Detection & Alarm Systems:

- Conventional Fire Alarm System
- Addressable Fire Alarm System
- Linear Heat Sensing System (LHS)

The danger posed by fire is constant. It makes no distinction between the time of day or day of the year. Therefore, you need a system that is always on watch, constantly alert and always ready to react instantly to a fire.

Our fire alarm systems cover all types of buildings with a range of alarms from basic wired detection through to complex multizone and wireless alarms.

To find out more about our Fire Detection and Alarm Services call on **+91-7892890889** or visit **www.pyrokinesistech.com**



Fire Hydrant System

Pyrokinesis Technology offers one of the oldest but most effective and widely used firefighting system, that is Fire hydrant system which is the basic from all the firefighting solutions.

Fire Hydrant system is designed to suppress the fire of huge proportions in all classes of fires. The fire hydrant system is the backbone of the firefighting systems in a building or premises. The purpose of the fire hydrant system is to provide a readily available source of water to any point throughout the building. This helps in controlling fire during an emergency.

The system is well designed and installed as per the NFPA-24 code, IS, NBC, FM, TAC and Local fire authorities PAN India basis.

Fire Sprinkler System

Pyrokinesis Technology provides a complete solution of fighting against intense fires without wasting much water. Automatic Fire Sprinkler Systems is based on water based protection systems. The Automatic Water Sprinkler System for firefighting or Water Monitor System for firefighting also has the provision for calculation of water demand using latest licensed hydraulic calculation software's which will accurately determine the water demand as per the standards.

We design Sprinkler System as Per Local Standard, NFPA-13, NBC & IS standards, the Various Types of Fire Sprinkler Systems are as below:

Wet Pipe Fire Sprinkler Systems

Deluge Fire Sprinkler Systems

Pre-Action Fire Sprinkler Systems

To find out more about our Fire Hydrant System & Fire Sprinkler System Services call on **+91-7892890889** or visit **www.pyrokinesistech.com**

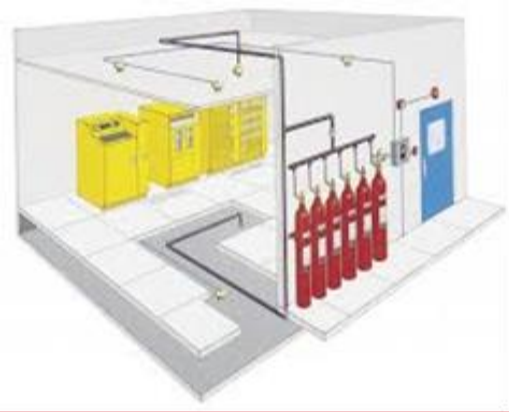

Fire Suppression Systems

innovation, engineering & fire prevention

Automatic fire suppression systems control and extinguish fires without the need for human intervention. We install, service and maintain a variety of fire suppression systems, both standalone and system integrated.

Clean Agent Fire Suppression System

FM-200, NAF S125, Inergen Clean Agent Fire Suppression System and others, all of which offer fast-acting, and most importantly, people-safe fire-suppressing solutions. Clean agents protect irreplaceable assets, such as computers, servers, electronics, artwork, archives and more, as they produce none of the damage often associated with traditional water sprinkler systems.

CO2 Systems

Provide a heavy blanket of gas that reduces the oxygen level to a point where combustion cannot occur. Because it's unsafe for people, CO2 is only recommended for localized applications or areas generally inaccessible by employees or customers.

Foam Suppression System

Foam Suppression System guard against virtually any hazard where flammable liquids are present. These hazards are common to a multitude of industries including Petrochemical, Chemical, Oil and Gas, Aviation, Marine/Offshore, Manufacturing, Utilities, Military, and Transportation.

Kitchen Fire Suppression System

Kitchen suppression systems can be installed within the cooker hood, or in adjacent cupboards, so that they are kept out of sight and don't take up a lot of space, even in the smallest of kitchens.

They protect a range of appliances, such as deep fat fryers, and oven hobs where hot oil is cooked. Chip pan blazes are a major risk in kitchens. According to the fire service, they are the biggest cause of fire-related injuries in the home – and it takes just seconds for a serious incident to occur.

To find out more about our Fire Suppression System and Services call on **+91-7892890889** or visit **www.pyrokinesistech.com**



Pyrokinesis Technology
(OPC) Private Limited

Pyrokinesis Technology is recognized as a startup by the Department for Promotion of Industry and Internal Trade having Certificate No.: **DIPP54182**

Get in touch

we'd love to hear from you

Pyrokinesis Technology (OPC) Pvt. Ltd.

CIN: U74999JH2019OPC013518

GSTIN: 20AAKCP7968H1Z2

Jamshedpur- Ramdeo Bagan, Golmuri,
Jamshedpur, Jharkhand- 831003

Patna- 8A/539, Chiraiyatand, Postal Park
Patna, Bihar-800001

Contact No.: +91-7892890889

+91-9654284766

Email: info@pyrokinesistech.com

Web: www.pyrokinesistech.com